

Scanner Digitizer Interface (SDI)

FEATURES

- ! 20:1 Reduction in ESP Thermal Errors
- ! Up to 90% Savings in Calibration Time
- ! Improved Diagnostic Capabilities
- ! Deranging Capability
- ! Compatibility with Conventional 8400 Systems

APPLICATIONS

- ! Windtunnel Test



The SDI configuration of the System 8400 represents a major advancement in electronic pressure scanning for windtunnel applications. This technology dramatically enhances data quality while equally increasing productivity. The system executes digital temperature compensation of ESP pressure scanner data to significantly improve overall accuracy and reduce the frequency of on-line calibrations as well as the time to perform them. This very compact unit digitizes all the analog signals near the scanners and transmits the data via fiber optic cable to the Fiber Interface Unit (FIU) in the 8400 System Processor. The FIU replaces the Scanner Digitizer Unit (SDU), while the remote SDI combines many of the features of the original SDU and its remote interface (IFC). Longer, yet smaller, cables are now possible between the 8400 System Processor and ESP scanners. Data quality is ensured since all analog data processing stays close to the scanners. Only digital data traverses the link between the SDI and FIU.

ESP scanners incorporating the Digital Temperature Compensation (DTC) option include factory generated pressure and temperature coefficients stored in an onboard EEPROM along with the calibration date and traceability. The scanner, used in conjunction with the SDI and FIU, also incorporates such features as deranging and per port temperature measurement. New diagnostic features include calibration valve position and excitation voltage sense that significantly decrease setup time.

Existing conventional 8400 systems can be upgraded to the SDI configuration with the addition of the new hardware and a firmware upgrade. Both conventional and DTC ESP scanners are supported by this new configuration.

SDI Specifications

Parameter	SDI Configuration		Units	Comments	
CONFIGURATION					
Type of ESP's Supported ¹	ESP-64HD ESP-48SL ESP-32HD			incorporating DTC option	
Number of FIU's Supported per 8400 SP	2		ea.	for 2048 channels, max	
Number of SDI's supported per FIU	1		ea.	for 1024 channels, max	
Number of ESP's supported per SDI	16		ea.	for 1024 channels, max	
PERFORMANCE					
Static Accuracy @ 100% Range	±0.03	%FS	after span cal	(ranges ≥ 5 psid)	
	±0.05	%FS	after rezero	(ranges ≥ 5 psid)	
	±0.06	%FS	after span cal	(ranges < 5 psid)	
	±0.10	%FS	after rezero	(ranges < 5 psid)	
	@ 33% Range ²	±0.05	%FS	after span cal	(ranges ≥ 5 psid)
		±0.08	%FS	after rezero	(ranges ≥ 5 psid)
±0.10		%FS	after span cal	(ranges < 5 psid)	
	±0.16	%FS	after rezero	(ranges < 5 psid)	
Total Thermal Stability @ 100% Range	±0.001	%FS/°C	typical	(ranges ≥ 5 psid)	
	±0.002	%FS/°C	worst case	(ranges ≥ 5 psid)	
	±0.002	%FS/°C	typical	(ranges < 5 psid)	
	±0.004	%FS/°C	worst case	(ranges < 5 psid)	
	@ 33% Range ²	±0.0015	%FS/°C	typical	(ranges ≥ 5 psid)
		±0.0025	%FS/°C	worst case	(ranges ≥ 5 psid)
	±0.003	%FS/°C	typical	(ranges < 5 psid)	
	±0.005	%FS/°C	worst case	(ranges < 5 psid)	
Measurement Rate ³	50,000		ch/sec	max (per FIU)	
A/D Resolution	16		bits	for SDI	
ELECTRICAL					
SDI ESP DTC SCANNERS					
Power Requirements ⁴ +5 volts +12 volts -12 volts		1200	90	ma	
		50	110	ma	
		50	40	ma	
				max (per ESP-64HD)	

Notes:

- 1 Conventional ESP scanners are also supported without Digital Temperature Compensation.
- 2 Accuracy is expressed as percent of the deranged Full Scale.
- 3 Will vary depending on frequency of temperature updates specified
- 4 Power supplied by FIU supports SDI and up to 4 each ESP-64HDs, max. Remote power supply is required for larger ESP configurations.

Specifications subject to change without notice.

Specifications SDI

Parameter	8426 FIU	8411 SDI	ESP (DTC) SCANNERS	Units	Comments
ENVIRONMENTAL/PHYSICAL					
Calibrated Temp Range			0 to 80	°C	
Operating Temp Range	0 to 50	0 to 80	-25 to 80	°C	
Storage Temp Range	-25 to 80	-25 to 80	-25 to 100	°C	
Size		4.25x1.89x2.13 10.81x4.80x5.40	3.15x1.35x1.00 8.02x3.46x2.55	in cm	L x W x H (for ESP-64HD)
Weight		14 400	7.0 195	oz g	max (for ESP-64HD)

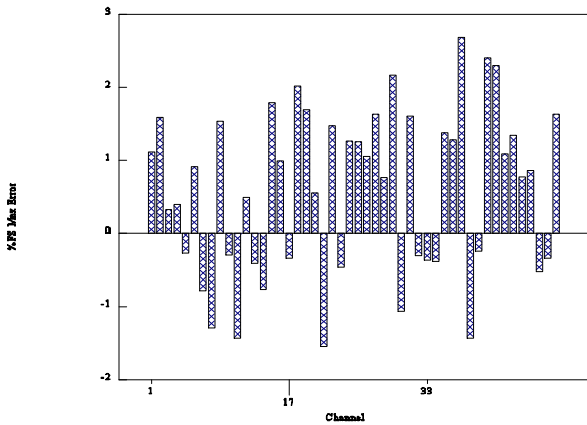

Maximum Thermal Error per Channel for an Uncompensated ESP Scanner with a 10 to 60°C Shift

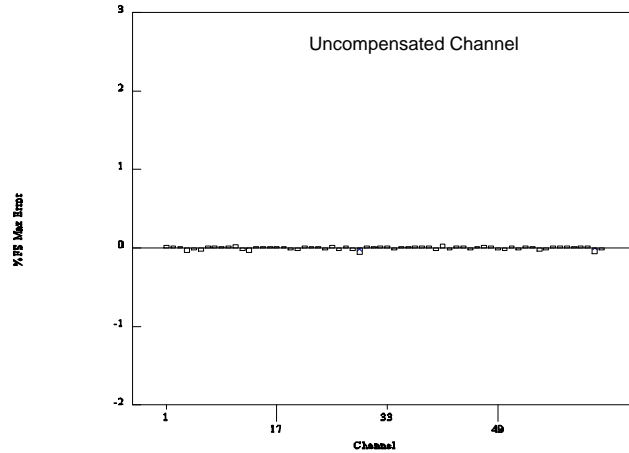

Maximum Thermal Error per Channel for a Compensated ESP Scanner with a 10 to 60°C Shift

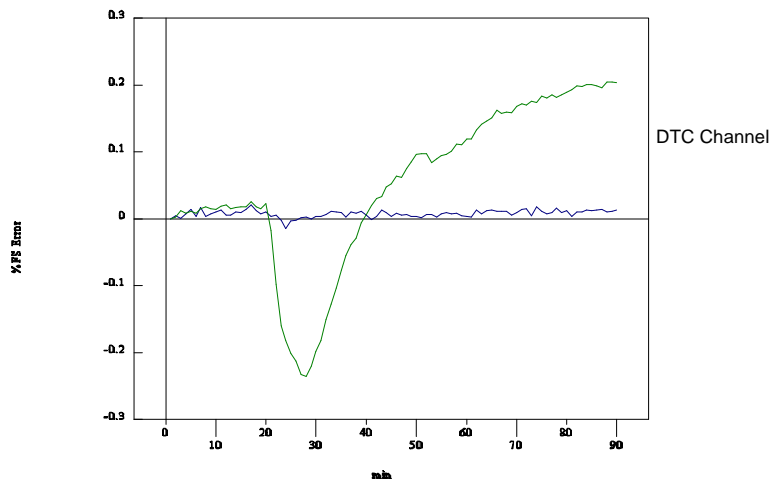

Typical Thermal Errors with Time for DTC Compensated and Uncompensated ESP Scanner with a 10 to 60°C Shift

SDI Theory of Operation

Development Background

The SDI configuration of the System 8400 was conceived to optimize the use of electronic pressure scanning in windtunnel applications. The single largest potential savings was the reduction of on-line calibrations required to maintain ESP accuracy in changing temperature environments. To achieve this, PSI employed our proven Digital Temperature Compensation technology, originally developed in the early 1980's and implemented in several successful products since then, including the S8256 Flight System and the 9000 Series Intelligent Pressure Scanners. To implement this technology in the miniature format of the ESP scanners while providing a user friendly configuration, required several challenges to be overcome. The end result incorporates several advanced technologies and yields an overall improvement in the technology of digital temperature compensation. In addition, the improved diagnostic capabilities derived from these enhancements serves to greatly minimize setup time.

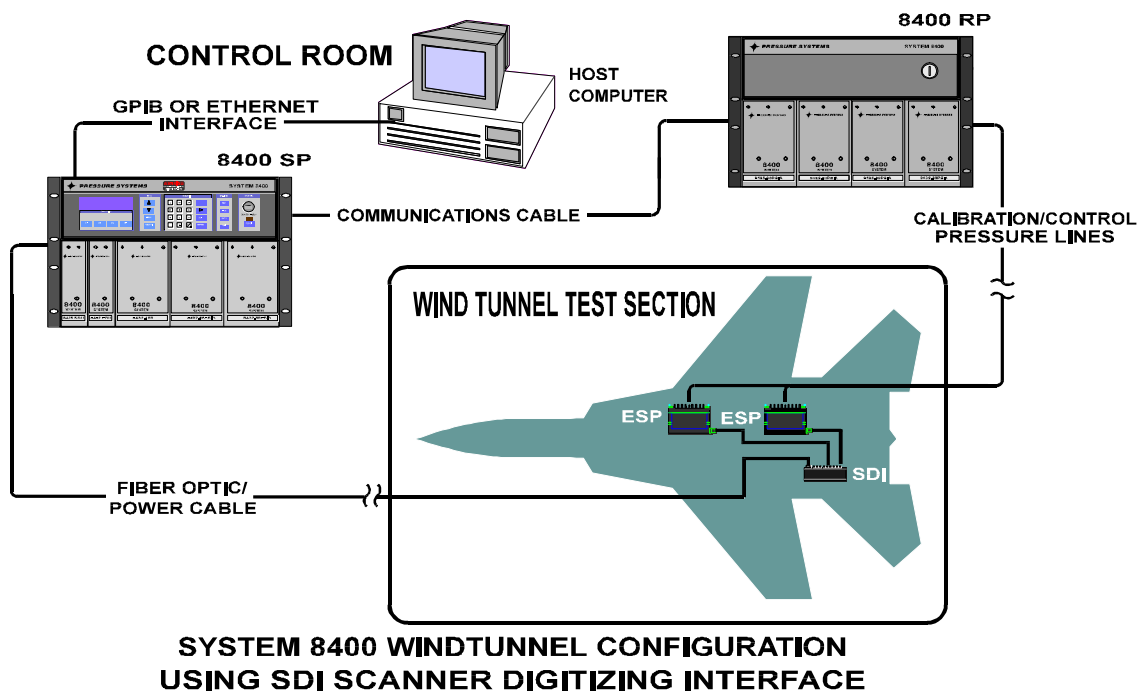

System Configuration

The SDI configuration consists of three basic components; the Fiber-optic Interface Unit (FIU), the Scanner Digitizer Interface (SDI) and the ESP Pressure Scanners incorporating the Digital Temperature Compensation (DTC) option.

The FIU is a single wide module installed within the 8400 System Processor and generally replaces the traditional SDU. The remotely located SDI combines much of the SDU and its 841FC functions. The FIU communicates with SDI via the 8474 fiber optic cable and transfers raw pressure data from the SDI into the VME memory of the System Processor for data reduction. One FIU can directly power up to 256 channels (four ESP-64HDs) using the 8473 power cable. An 8491 Remote Power Supply is required for larger ESP configurations. Configurations using up to two FIUs and/or SDIs can be accommodated.

SDI Theory of Operation

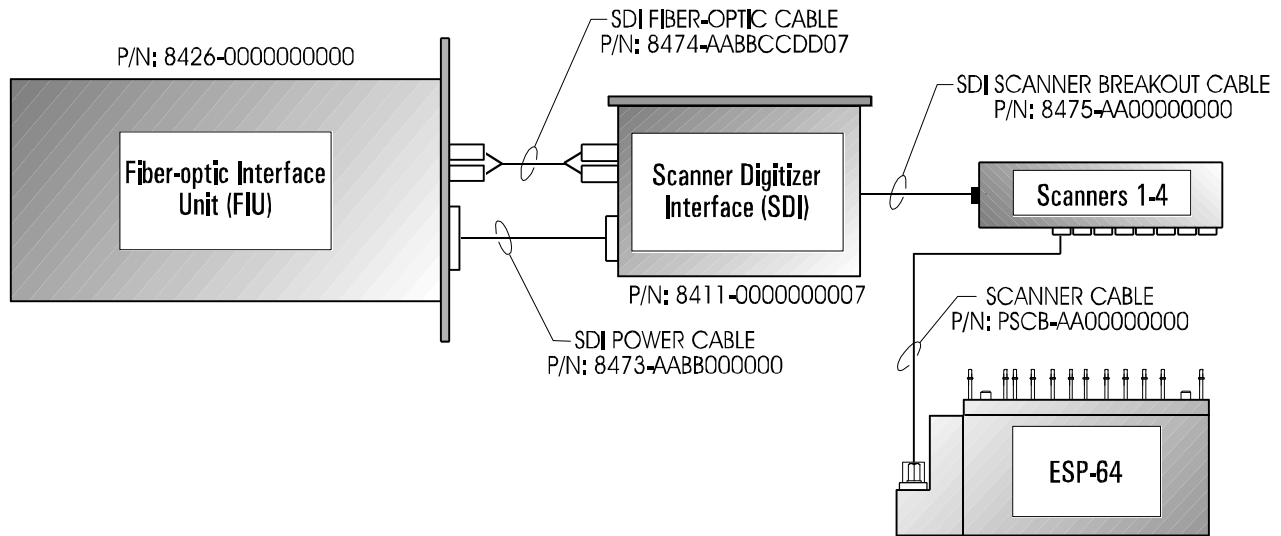

SDI Configuration for up to 256 Channels

The SDI is designed to be placed in or near the model as space permits. The 8475 scanner breakout cables connect up to eight ESP scanners to each of two electrical connectors on the SDI to support a total of sixteen scanners. From the breakout cable, PSCB scanner cables are used to connected each of the ESP scanners.

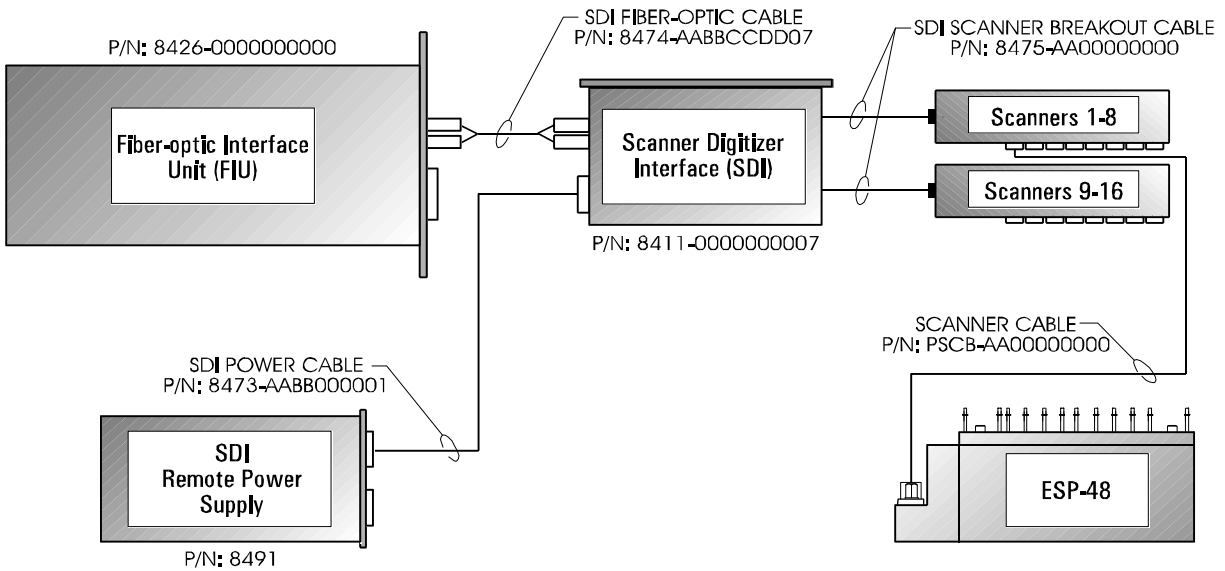

SDI Configuration for up to 1024 Channels

SDI Theory of Operation

Scanner Digitizer Interface (SDI)

The SDI configuration addresses and digitizes the analog data in or near the model where the ESP Pressure Scanners are located. This eliminates sources of errors associated with routing analog signals through long lengths of cables.

The SDI incorporates a 16-bit A/D converter as well as circuitry to control the ESP scanners and communicate with the 8400 System via an advanced high speed fiber optic interface. The use of fiber optic communication minimizes the cable size while increasing the distance from the system to the ESP scanners.

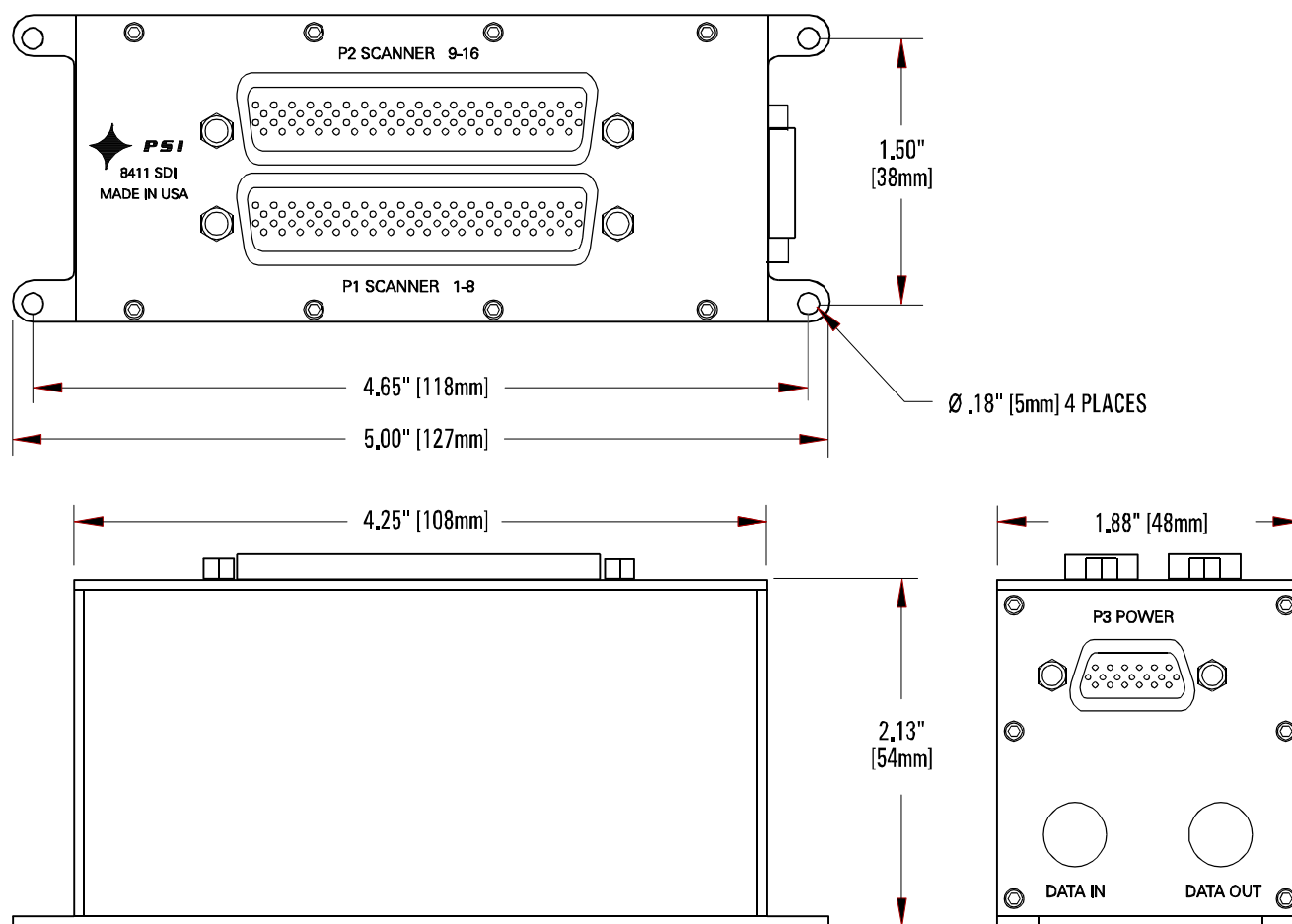

Scanner Digitizer Interface (PN: 8411)

Theory of Operation SDI

ESP Pressure Scanners

The DTC option of the ESP pressure scanners incorporates many advanced features to increase the utility of the scanners while providing digital temperature compensation of the silicon sensors.

An onboard EEPROM stores the thermal calibration data for each channel. Also stored in the EEPROM is information identifying the range of the scanner, the number of channels, the model number, the serial number, the date of manufacturer, the date of calibration, and the model and serial number of the calibration unit used to calibrate the scanner. This data is serially transmitted to the SDI using the ESP address lines and then transferred to the System Processor via the fiber optic cable.

Using a proprietary PSI-developed method, the temperature of each sensor within the scanner is measured and transmitted along with the raw pressure measurements to the system. The frequency of these temperature updates is user specified to balance data acquisition speed with compensation requirements.

The ESP scanners also incorporate a hall effect sensor which is used to indicate the position of the calibration manifold. This position information can be transferred to the system upon command.

Another advanced feature is the ability to derange the ESP scanner upon command. This alters the gain on the amplifier to derange the scanner by a factor of three, enabling additional windtunnel tests to be conducted without reinstrumenting the model with lower range ESP scanners. The calibration coefficients within the EEPROM are developed to maximize the accuracy of the scanner at the lower range.

The DTC option for the ESP scanners only slightly increases the length of the scanner to accommodate the additional components.

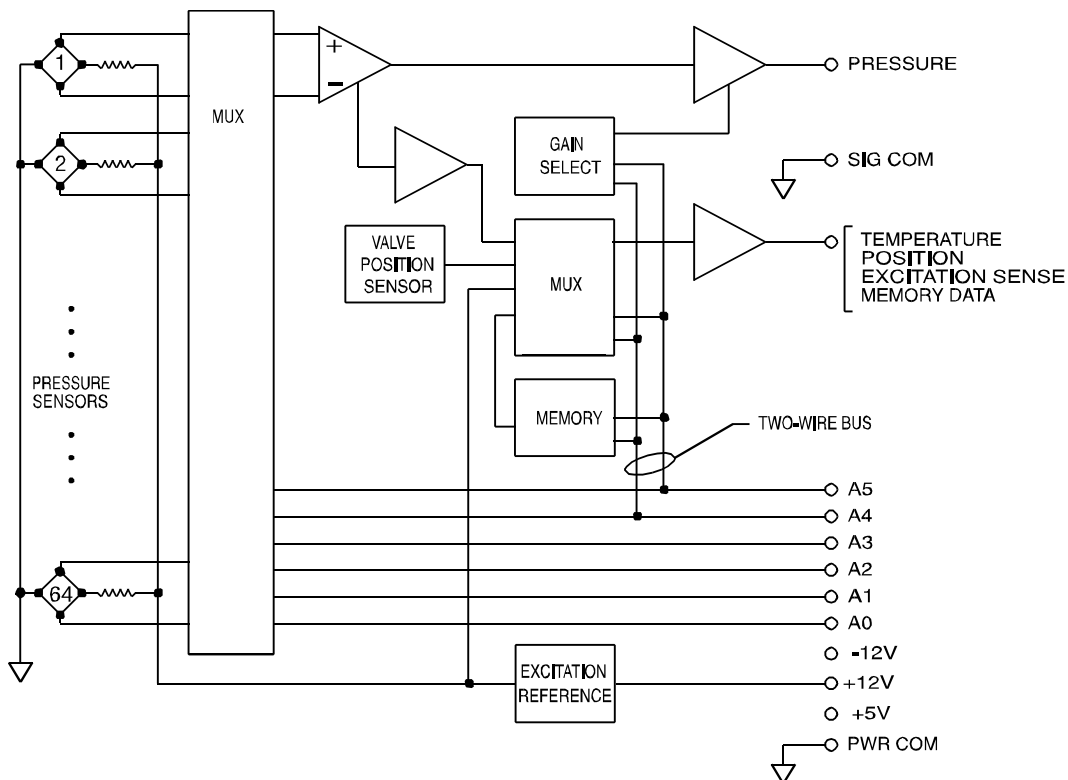

SDI Ordering Information

PN: 8426-AA00000000 8400 Fiber-Optic Interface Unit

AA = Connection Type
 00, Fiber-optic
 01, 2 wire

PN: 8411-00000000EE 8400 Scanner Digitizer Interface

EE = Connection Type
 07, Fiber-optic
 08, 2 wire

PN: PSCB-AA00000000 Scanner Cable (30' max)
 PN: 8473-AABB000000 SDI Power Cable (100' max) AA, BB, CC, DD = Length
 PN: 8474-AABBCCDD07 SDI Fiber-Optic Interface Cable

PN: 8475-AA00000000 SDI/Scanner Breakout Cable
 PN: 32HD-AABBCC1000 ESP-32HD (DTC) Scanner, 32 Port
 PN: 48SL-AABBCC1000 ESP-48SL (DTC) Scanner, 48 Port
 PN: 64HD-AABBCC1000 ESP-64HD (DTC) Scanner, 64 Port

AA = Pressure Range (Consult factory for pressure ranges not listed)

01, ±10"WC (2.5 kPa)	06, ±10 psid (70 kPa)
02, ±20"WC (5.0 kPa)	07, ±15 psid (100 kPa)
03, ±1 psid (7 kPa)	08, ±30 psid (210 kPa)
04, ±2.5 psid (17 kPa)	09, ±45 psid (310 kPa)
05, ±5 psid (35 kPa)	10, +100 psid (700 kPa)

BB = Pneumatic Connection

01, .040", 90°
 02, .040", 45°
 03, .063", 90°

CC = Purge

00, Standard
 02, Purge option

Notes: BB Option
 03 Not available on ESP-64HD
 02 Not available with Purge

Order Example:

64HD-0702001000 ESP-64HD Scanner, ±15 psid, .040, 45°, DTC option

