

DESCRIPTION

molstic molbloc mounting systems are available to assist you in realizing the full performance benefits of your molbloc/molbox™ system. molstics provide an engineered solution to the practical issues of mounting the molbloc, connecting a gas supply, regulating the pressure and connecting the device to be tested. Highest quality components are integrated into a compact assembly to assure optimum molbloc/molbox performance.

molstics provide a quick connector input for convenient connection to the gas supply. This is followed by a 2 micron (0.5 micron for lo flow) filter to protect the downstream components. Then, an adjustable regulator sets and regulates optimum molbloc upstream pressure and protects the molbox

transducers against accidental overpressure. The regulator range supports all standard molbloc operating pressure ranges. A bellows shut-off valve, just before the molbloc, allows the gas supply to be shut-off for configuration changes and/or system leak checking. Special cradles support the molbloc(s). A connection and pads are provided downstream of the molbloc for mounting the MFC (mass flow controller), another device under test, or the optional metering valve kit for manual flow control.

Single channel molstics are available to accommodate single molblocs. Dual channel models allow two molblocs to be

mounted simultaneously to switch between two different molbloc ranges without changing hardware or to take advantage of molbox1's capability to run two molblocs in parallel.

There are low, mid and high flow versions of molstic. Low flow molstics use a unique, very high stability pressure regulator and minimize dead volumes. They are required for effective use of 2E2 and lower molblocs and can be used up to the 1E3 molbloc size. The mid flow molstics cover the ranges of all the molblocs from as low 2E2 up to the 3E4. The high flow molstic is required for the 1E5 (100 slm) molbloc and supports that molbloc only.

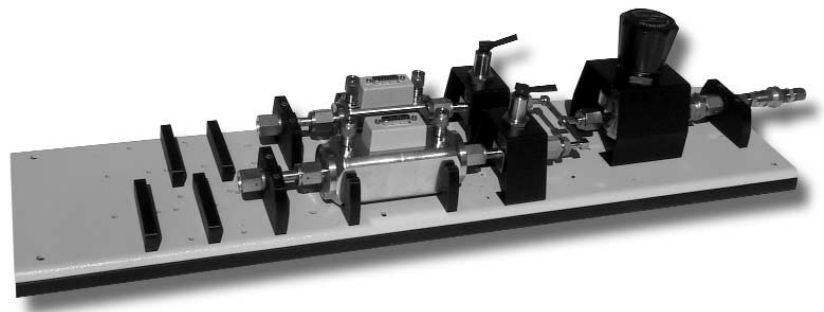

single, lo flow

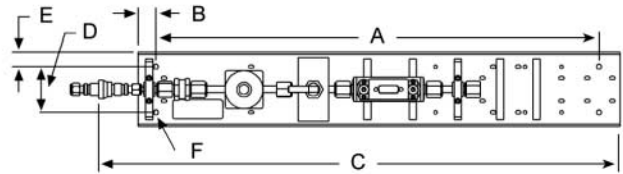
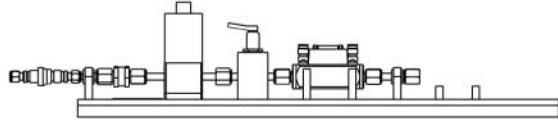

dual, mid flow

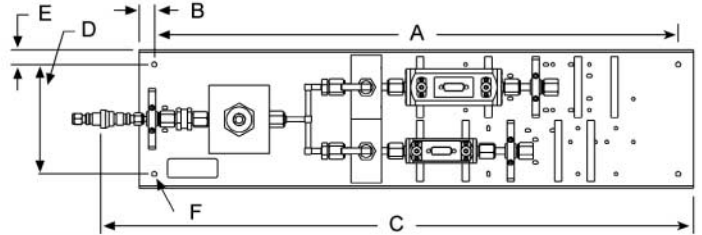

single, hi flow

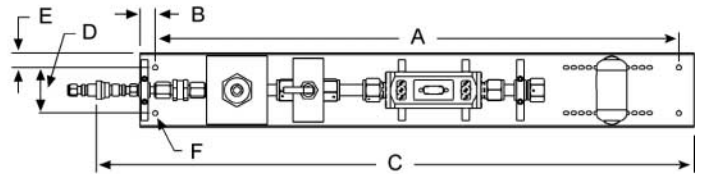
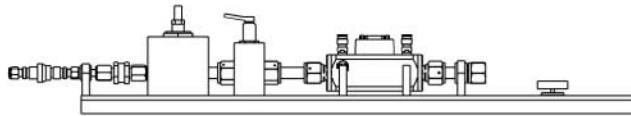

DIMENSIONS

molstic	A	B	C	D	E	F
single, low flow	584 [22.99]	26 [1.02]	687.3 [27.06]	60 [2.36]	19 [0.75]	6.40 [0.252] Mounting Holes, 4 PL
dual, mid flow	690 [27.17]	20 [0.79]	752.4 [29.62]	144 [5.67]	19 [0.75]	6.40 [0.252] Mounting Holes, 4 PL
single, hi flow	690 [27.17]	20 [0.79]	787.7 [31.01]	60 [2.36]	19 [0.75]	6.40 [0.252] Mounting Holes, 4 PL

mm [in.]

ORDERING INFORMATION

molstics

DESIGNATOR	DESCRIPTION	PART NUMBER	PURPOSE
molstic	single, lo flow	401316	Single molbloc, 1E3 or lower
molstic	dual, lo flow	401318	Two molblobs, 1E3 or lower
molstic	single, mid flow	401244	Single molbloc, 2E2 to 3E4
molstic	dual, mid flow	401317	Two molblobs, 2E2 to 3E4
molstic	single, hi flow	401663	Single molbloc, 1E5 only

ACCESSORIES

DESIGNATOR	DESCRIPTION	PART NUMBER	PURPOSE
Tee, Downstream, lrg/sml	for dual mid molstic	122581	Connect two same size molblobs together at outlet
Tee, Downstream	for dual mid molstic	401324	Connect large and small size molblobs together at outlet
Metering Valve	lo flow molstic	401319	Install on molstic downstream of molbloc for manual flow control
Metering Valve	mid flow molstic	401320	Install on molstic downstream of molbloc for manual flow control
Metering Valve	hi flow molstic	401666	Install a molstic downstream of molbloc for manual flow control

CONFIGURATION NOTES

- 1E1 to 5E3 molblobs are "small" molblobs. 1E4 to 1E5 molblobs are "large" molblobs. The 1E5 molbloc is unique due to its end fittings.
- The hi flow molstic supports only the 1E5 molbloc with 1/2 in. VCR male end fittings. Lo and mid flow molstics can only be used with molblobs having 1/4 in. VCR male end fittings (1E1 to 3E4 molblobs).
- The downstream connection of lo and mid flow molstics is 1/4 in. VCR female and an adaptor to 1/4 in. Swage male is provided. The downstream connection of the hi flow molstic is 1/2 in. VCR female and a 1/4 in. VCR female adaptor is provided.
- The optimum range distribution between lo and mid flow molstics is lo for molblobs of 1E3 and below and hi for molblobs from 5E3 to 3E4. The 1E5 molbloc requires the hi flow molstic which supports no other molbloc size.
- Mid molstics are designed to mount either large or small sized molblobs. Same size molblobs can be interchanged quickly on any molstic. More effort is required to interchange molblobs of different sizes.

molstic, molbloc and molbox are trademarks, registered and otherwise, of DH Instruments, Inc.

VCR and Swagelok are trademarks of the Swagelok Companies.

Due to a policy of continual product improvement, product specifications, descriptions and features are subject to change without notice.

DH Instruments, Inc.
4765 East Beautiful Lane
Phoenix, AZ 85044-5318
USA



**Calibration Solutions
for Pressure
and Flow™**

Tel 602.431.9100
Fax 602.431.9559
dhi@dhinstruments.com
www.dhinstruments.com